

# DMEG170-R



## Diabie monte-escaliers électrique aluminium avec bras rotatif et repliable 170 kg

### LES + PRODUIT

- Capacité de 170 kg
- Entièrement repliable, hauteur 770 mm
- Timon ajustable et inclinable
- Bavette en aluminium rabattable
- Châssis aluminium avec bloc motorisation IP 54
- Système de connexion rapide de la batterie
- Equipé de série d'oreilles de protection en polypropylène
- Livré de série avec roues increvables
- Livré avec chargeur, batterie et sangle de maintien

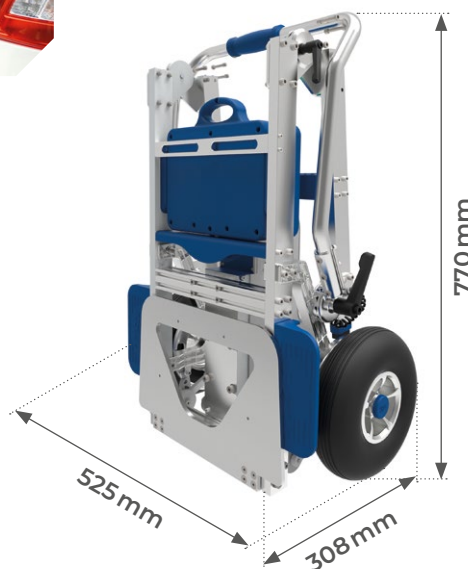

Modèle		DMEG170-R
Capacité	kg	170
Dimensions hors tout (L x P x h)	mm	525 x 540 x 1590
Dimensions replié (L x P x h)	mm	525 x 308 x 770
Dimensions bavette (L x P)	mm	400 x 240
Vitesse de montée	min	24 à 34 marches
Type de batterie		lithium
Batterie	V/Ah	48/10
Poids de la batterie	kg	3
Temps de charge	h	3
Indice de protection		IP54
Largeur marche (mini)	mm	250
Hauteur marche (maxi)	mm	210
Roues increvables	mm	Ø 260
Poids	kg	25

## OPTIONS ET ACCESSOIRES POUR DIABLES MOTORISÉS ERGONOMIQUES



**DME170/E-OP007**  
Béquille brancard



**DME170/E-OP002**  
Equipement double porte-bouteille



Double



**DME170/E-OP006**  
Châssis roulant  
550x400 mm



**DME170/E-OP008**  
Porte bonbonnes d'eau



**DME170/E-OP003**  
Extension latérale

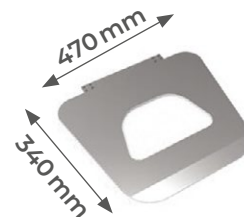

**DME170/E-OP004**  
Grande bavette  
470x340 mm



**DME170/E-PD002**  
Batterie supplémentaire



**DME170/E-PD003**  
Chargeur standard



**DME170/E-PD004**  
Sangle de sécurité



**ELS420**  
Système de levage  
électrique pour CT420



**CT420RAMP**  
Rampe pour CT420



**SBH**  
Crochets de maintien  
pour bacs